

Werkzeug-Wandregal für Akku-Werkzeuge

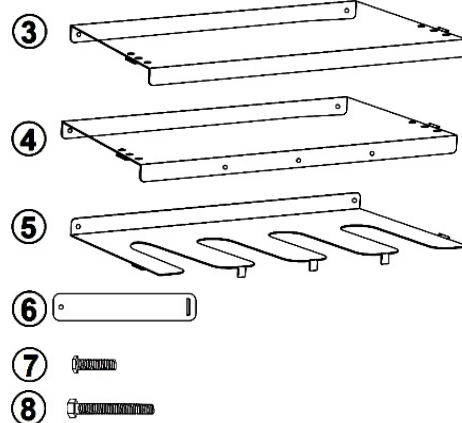

TEILE

- 1 Stahlblech linke Seite
- 2 Stahlblech rechte Seite
- 3 Oberes Stahlblech
- 4 Mittleres Stahlblech
- 5 Unteres Stahlblech
- 6 Kleines Stahlblech (x3)
- 7 Schraube M4 x 8mm (x9)
- 8 Schraube M5 x 50mm (x2)

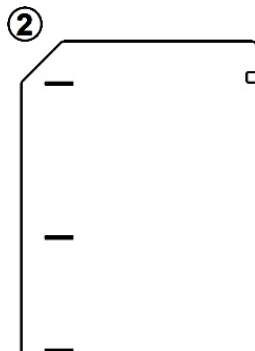
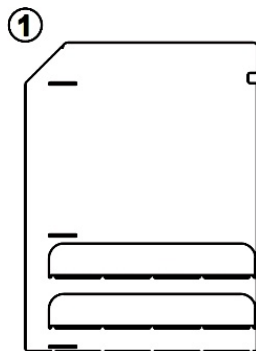

MONTAGEANLEITUNG**Schritt 1**

Montieren Sie das linke Stahlblech (1),
das rechte Stahlblech (2) und das untere
Stahlblech (5) mit den Schrauben (7)
M4 x 8 mm.

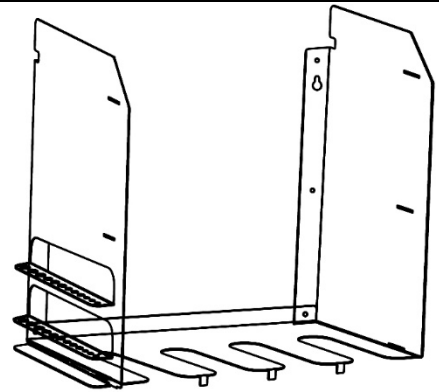
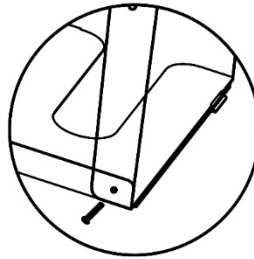
**Schritt 2**

Montieren Sie das mittlere Stahlblech (4)
mit den Schrauben (7) M4 x 8 mm
am Rack.

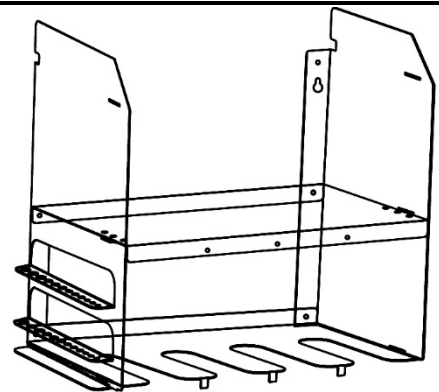
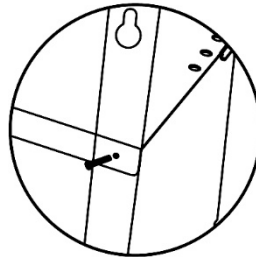
**Schritt 3**

Montieren Sie das obere Stahlblech (3)
mit den Schrauben (7) M4 x 8 mm
am Rack.

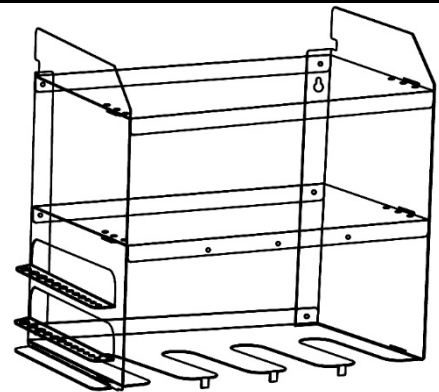
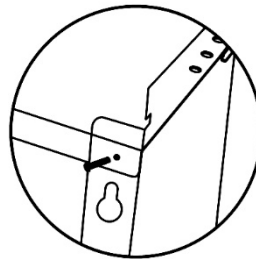
**Schritt 4**

Der letzte Schritt besteht darin, die 3
kleinen Stahlbleche (6) zwischen dem
mittleren Stahlblech (4) und dem unteren
Stahlblech (5) zu montieren.

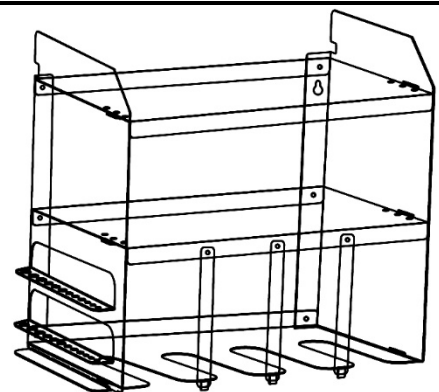
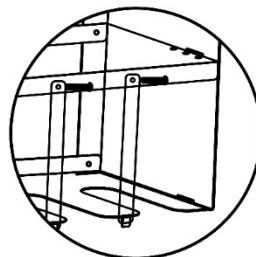

Cordless Power Tool Shelving Storage Rack



PARTS

- 1 Left side steel plate
- 2 Right side steel plate
- 3 Top steel plate
- 4 Middle steel plate
- 5 Bottom steel plate
- 6 Small steel plate (x3)
- 7 M4 x 8mm screw (x9)
- 8 M5 x 50mm screw (x2)

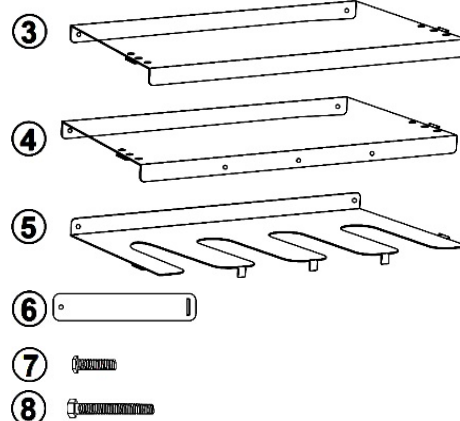
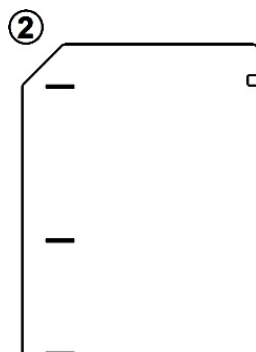
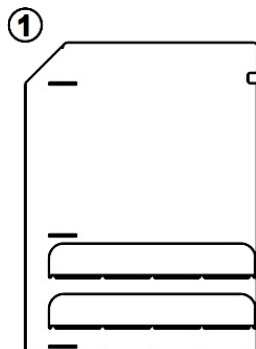

ASSEMBLY INSTRUCTION**Step 1**

Assemble the left side steel plate (1), right side steel plate (2) and bottom steel plate (5) with M4 x 8mm screws (7).

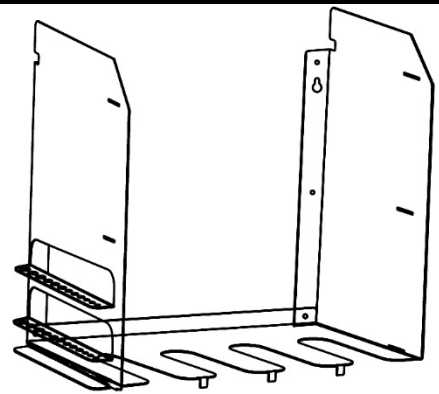
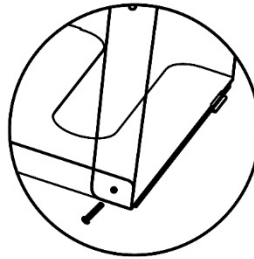
**Step 2**

Assemble the middle steel plate (4) on the rack with M4 x 8mm screws (7).

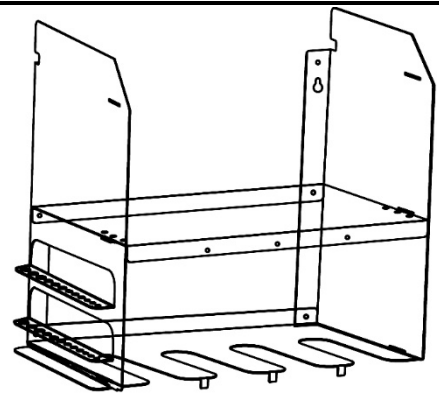
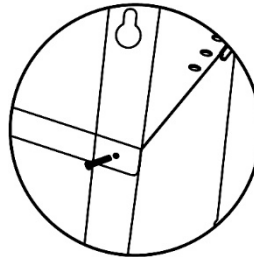
**Step 3**

Assemble the top steel plate (3) on the rack with M4 x 8mm screws (7).

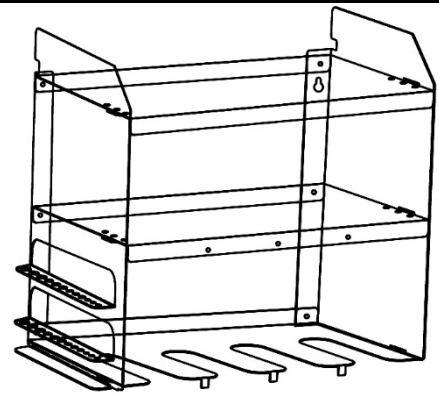
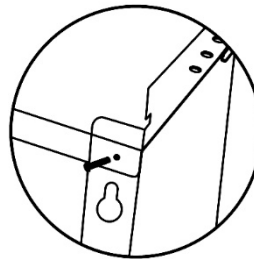
**Step 4**

The final step is to put the 3 small steel plates (6) between the middle steel plate (4) and bottom steel plate (5).

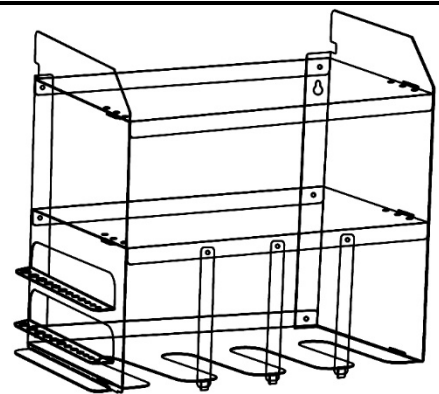
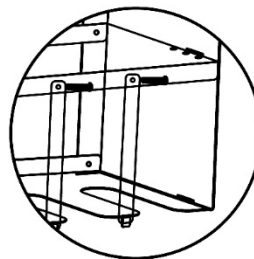

Étagère murale pour outils sans fils



COMPOSANTS

- 1 Tôle d'acier côté gauche
- 2 Tôle d'acier côté droit
- 3 Tôle d'acier supérieure
- 4 Tôle d'acier centrale
- 5 Tôle d'acier inférieure
- 6 Petite tôle d'acier (3 pièces)
- 7 Vis M4 x 8 mm (9 pièces)
- 8 Vis M5 x 50 mm (2 pièces)

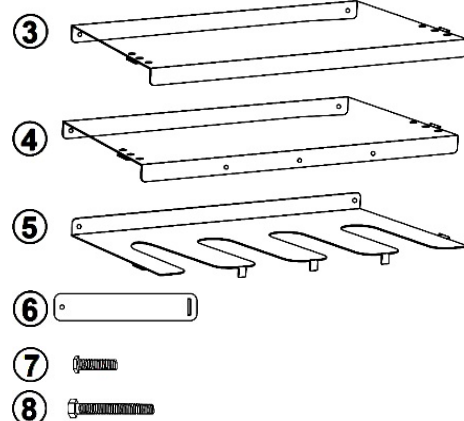
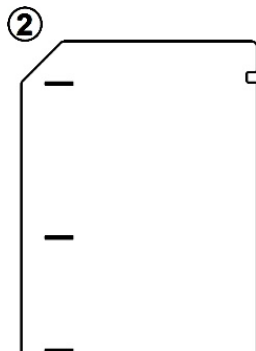
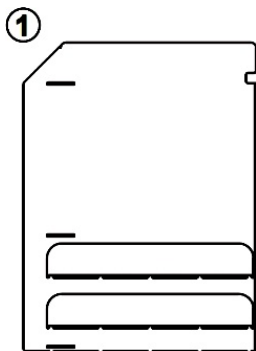

NOTICE DE MONTAGE**Étape 1**

Montez la tôle d'acier gauche (1), la tôle d'acier droite (2) et la tôle d'acier inférieure (5) à l'aide des vis M4 x 8 mm (7).

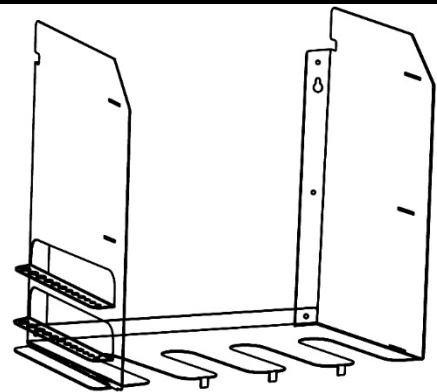
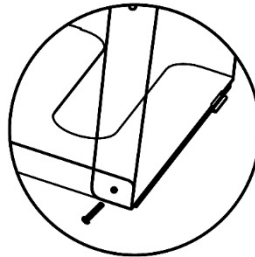
**Étape 2**

Montez la tôle d'acier centrale (4) à l'aide des vis M x 8 mm (7) dans le cadre.

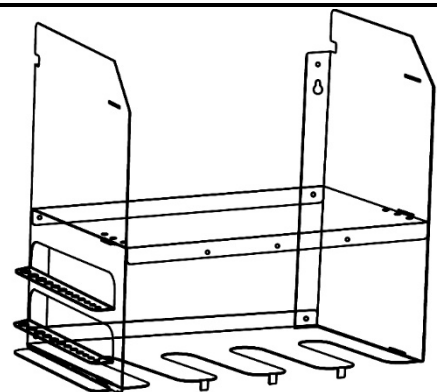
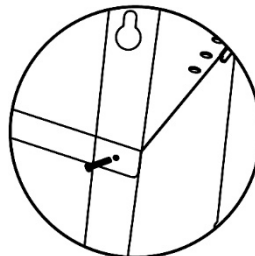
**Étape 3**

Montez la tôle d'acier supérieure (3) à l'aide des vis M x 8 mm (7) dans le cadre.

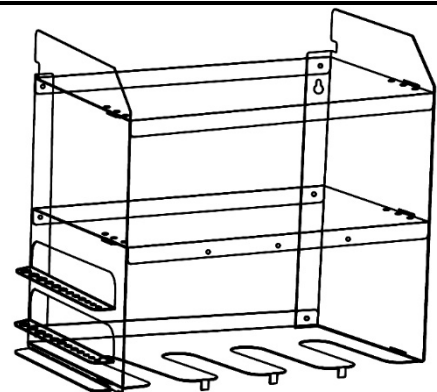
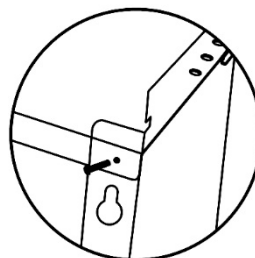
**Étape 4**

La dernière étape consiste à monter les 3 petites tôles d'acier (6) entre la tôle d'acier centrale (4) et la tôle d'acier inférieure (5).

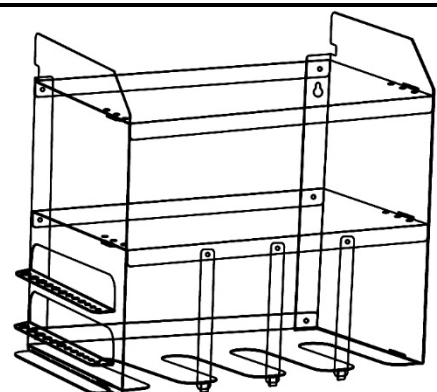
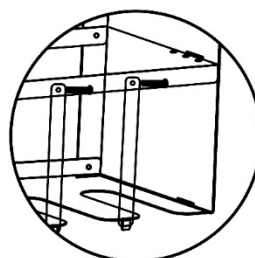

Estante de pared para herramientas a batería



PIEZAS

- 1 Chapa de acero lado izquierdo
- 2 Chapa de acero lado derecho
- 3 Chapa de acero superior
- 4 Chapa de acero intermedia
- 5 Chapa de acero inferior
- 6 Chapa de acero pequeña (x3)
- 7 Tornillo M4 x 8mm (x9)
- 8 Tornillo M5 x 50mm (x2)

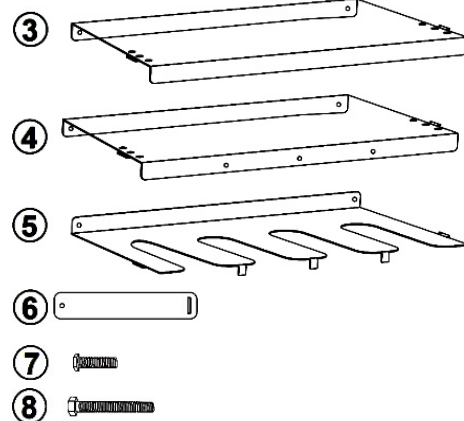
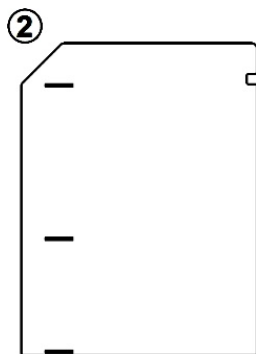
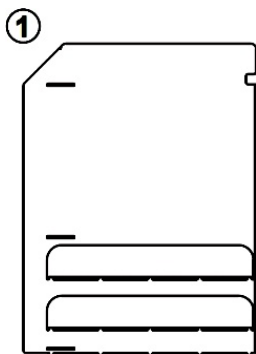

INSTRUCCIONES DE MONTAJE**Paso 1**

Monte la placa de acero izquierda (1), la placa de acero derecha (2) y la placa de acero inferior (5) con los tornillos (7) M4 x 8 mm.

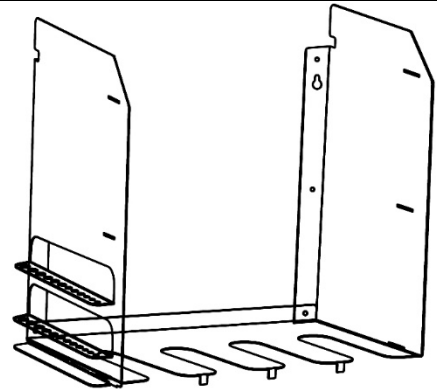
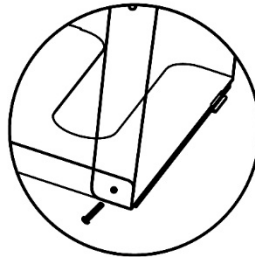
**INSTRUCCIONES DE MONTAJE****Paso 2**

Monte la placa de acero intermedia (4) en el estante con los tornillos M4 x 8 mm (7).

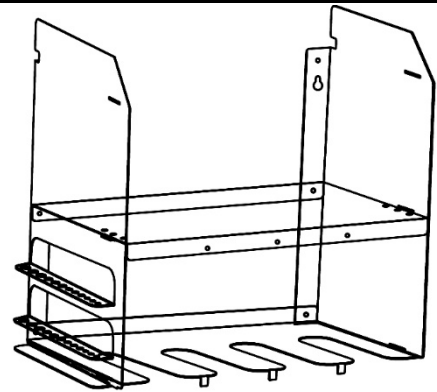
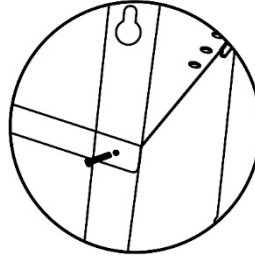
**Paso 3**

Monte la placa de acero superior (3) en el estante con los tornillos (7) M4 x 8 mm.

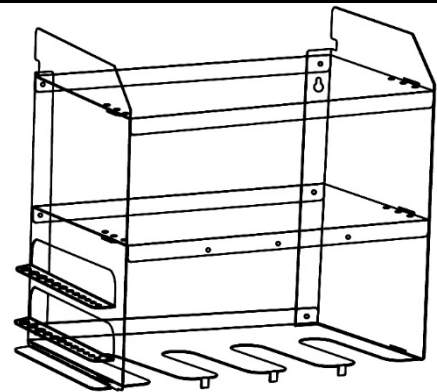
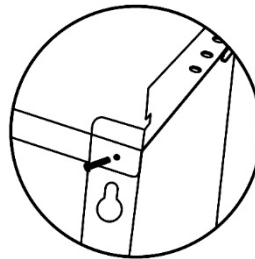
**Paso 4**

El último paso consiste en montar las 3 chapas de acero pequeñas (6) entre la chapa de acero intermedia (4) y la chapa de acero inferior (5).

